

---

# User Manual

RP 480i Remote Panel



# auto MASKIN

## Table of content

<b>1 About this manual</b>	<b>2</b>	7.1.1 Display	20
1.1 Intended audience	2	7.1.2 Units	21
1.2 Responsibilities	3	7.1.3 Language	21
1.3 Revisions	3	7.1.4 Touch Feedback	21
1.3.1 Software revisions	3	7.2 Display	21
1.3.2 User Manual revision	3	7.2.1 Brightness	22
<b>2 Overview</b>	<b>4</b>	7.2.2 Mode	22
2.1 Introduction to RP 480i and Marine Pro	4	7.2.3 Clean Screen	22
2.2 RP 480i Remote Panel	5	7.2.4 Wallpaper	22
2.2.1 Hardware Connections	5	7.2.5 Home Page Layout	23
2.2.2 Physical Operator Interface	6	7.2.6 Engine Order	23
<b>3 First Power On</b>	<b>7</b>	7.3 Engines	24
3.1 Change PIN	7	7.3.1 Engine Selection	24
3.2 Network	8	7.3.2 Engine Specific Functionality	24
3.3 Done	8	7.4 Troubleshooting	26
<b>4 The RP480i User Interface</b>	<b>9</b>	7.4.1 This Panel	26
4.1 Header Information	9	7.4.2 Communication	27
4.1.1 Header Information – Multiple Engines	9	7.4.3 Diagnostics	27
4.1.2 Header Information – Single Engine	9	7.5 Administration (User Accessible)	28
4.1.3 Header Status Symbols	10	<b>8 Administration Menu</b>	<b>29</b>
4.2 Instrument View	11	8.1 This Panel	29
4.2.1 Home Page	11	8.1.1 Panel Location	30
4.2.1.1 Home Page - Multiple Engines	11	8.1.2 Panel Priority	30
4.2.2 Home Page - Single Engine	12	8.1.3 Network	31
4.2.3 Focused Engine View	12	8.1.4 Start/Stop Buttons	31
<b>5 Start and Stop of engines</b>	<b>14</b>	8.1.5 DCU Alarms	31
5.1 Start an engine - One connected DCU	14	8.2 DCU Connections	31
5.2 Stop an engine - One connected DCU	14	8.3 Acknowledge	32
5.3 Start and Stop an engine - Multiple connected DCUs	15	8.4 I/O Configuration	33
5.4 Start and Stop multiple engines simultaneously	15	8.4.1 Flexible I/O	33
<b>6 Alarm List</b>	<b>16</b>	8.4.2 Input Functions	33
6.1 Filter Section	16	8.4.3 Output Functions	34
6.2 Event section	17	8.5 Security	35
6.3 Acknowledgement of events	19	8.5.1 PIN	35
<b>7 Operator Menu</b>	<b>20</b>	8.5.2 Web Server	35
7.1 Quick Controls	20	8.5.3 SSH Server	35
		8.6 Maintenance	35
		8.6.1 Panel Maintenance	35

# 1 About this manual

## 1.1 Intended audience

This manual has been published primarily for professionals and qualified personnel. The user of this material is assumed to have basic knowledge in marine systems and must be able to carry out related electrical work.



Work on the low-voltage circuit should only be carried out by qualified and experienced personnel.

Installation or work on the shore power equipment *must only* be carried out by electricians authorized to work with such installations.

## 1.2 Responsibilities

It is the **sole responsibility of the installer** to ensure that the installation work is carried out in a satisfactory manner, that it is operationally in good order, that the approved material and accessories are used and that the installation meets all applicable rules and regulations.



Auto-Maskin continuously upgrades its products and reserves the right to make changes and improvements without prior notice.

All information in this manual is based upon information at the time of printing. For updated information, please contact your local distributor.



The crossed-out wheeled bin symbol indicates that the item should be disposed of separately. The item should be handed in for recycling in accordance with local environmental regulations for waste disposal.

By separating a marked item, you will help reduce the volume of waste sent to incinerators or land-fill and minimize any potential negative impact on human health and the environment.

## 1.3 Revisions

### 1.3.1 Software revisions

This version of the document is synchronized with firmware version: 3.11 P2

### 1.3.2 User Manual revision

User manual revision: November 2022, first revision.

## 2 Overview

### 2.1 Introduction to RP 480i and Marine Pro

The RP 480i is the latest addition to the Marine Pro 400 Series lineup. It is a Remote Panel compatible with all existing Marine Pro components, and can be used in combination with other models of Remote Panels and Engine Controllers, for example the RP 410E and the DCU 410E.

As all Marine Pro 400 Series products the RP 480i is IACS certified.

Example architecture with various Marine Pro components:

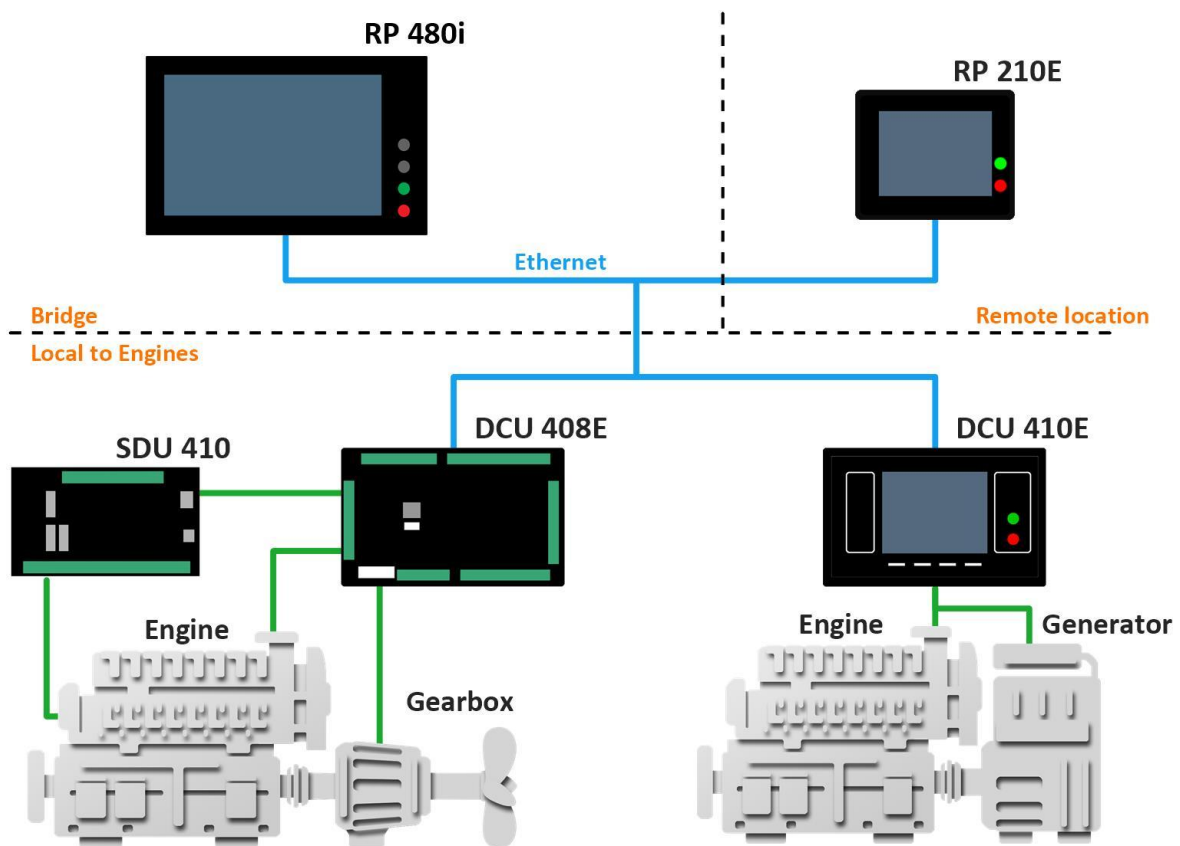

## 2.2 RP 480i Remote Panel

### 2.2.1 Hardware Connections

The rear side of the RP 480i has the following interfaces.



#### Connection Interfaces



- 6. NMEA 2000\* (isolated)
- 7. Ethernet 2 RJ45\*
- 8. Ethernet 1 RJ45 (for network communication)
- 9. 2x USB-A
- 10. USB-A
- 11. HDMI out\*



- 1. CAN bus\*
- 2. Relay\*
- 3. Modbus RTU\*
- 4. Flexible I/O
- 5. Power supply 12 V / 24 V

\* not supported

Connectivity	
Power Supply	12 V / 24 V
USB	USB 2.0 High-speed interface Reserved for software update
Ethernet 1	RJ45. Used for networking.
Miscellaneous	
Buzzer	Activates for any new event.
Ambient Light Sensor	Automatic adjustment of screen brightness.
Proximity Sensor	Motion detection.

### 2.2.2 Physical Operator Interface

The RP 480 is controlled either through its touch screen interface or using its four hard buttons.

The buttons on the right-hand side of the panel are used to control different parts of the panel as described below:

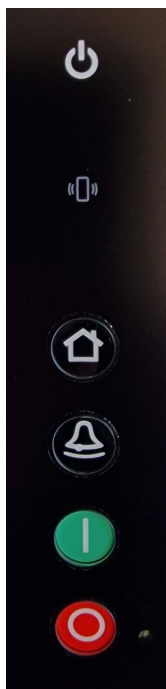

Interface	
Power Indication	Lit when the panel is powered.
NFC Interface	Not used in this software revision.
Home Button	Toggles the Alarm and Menu page, and the optional Home page.
Alarm Button	Silence the buzzer or advance to the next page with events.
Start Button	Start Engines
Stop Button	Stops Engines

## 3 First Power On

When starting up a RP 480i for the first time (or after a Factory Reset) a special form is shown to aid in basic configuration.

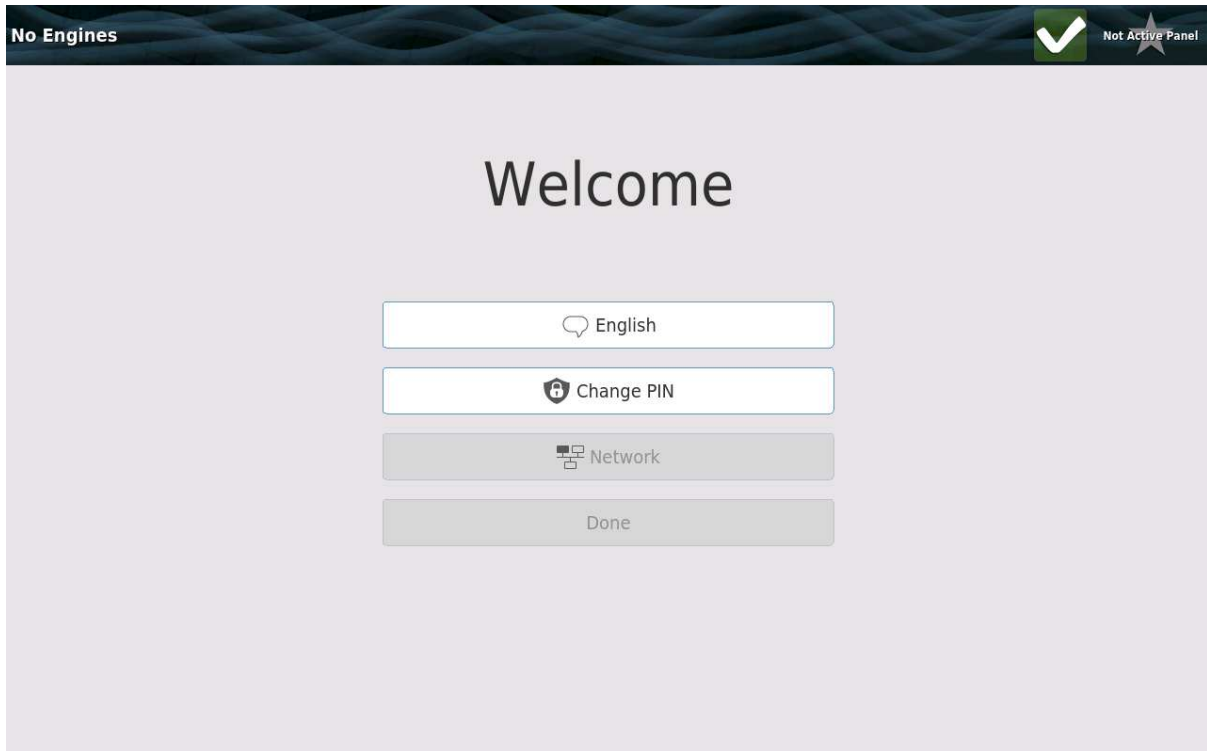

This “Startup Wizard” must be completed before the RP 480i can be connected to any Engine Controllers and taken into use.

To complete the Wizard the PIN code and Network configuration must be performed. Once these steps have been carried out, press Done to exit the Wizard.



See the Chapter below called Administration Menu for a complete set of configuration options, including how to connect to Engine Controllers.

### 3.1 Change PIN

Press the Change PIN button to assign a new PIN code. The default PIN is 1234. It is advisable to change to another code other than the default.



Important! Take note of the chosen PIN code. Without access to the correct PIN code reconfiguration of the panel cannot be performed.

If you fail to input the correct PIN code, the PIN code dialog provides a 5 digit encrypted number. If you can't remember your PIN code, take note of this

encrypted number and contact your representative for help on how to restore access.

### 3.2 Network

Press this button to configure the IP number of the Remote Panel.

This button is enabled when the PIN code has been configured.

### 3.3 Done

This button is enabled after all required steps have been performed. Press to exit the wizard.



## 4 The RP480i User Interface

### 4.1 Header Information

The RP 480i features a header that's always shown independent of which form is currently shown. The header only displays information to the operator, i.e. the header has no clickable elements that reacts to operator input.

The information shown on the header changes based on the number of engines controlled by the RP 480i and what form is currently shown on the panel.

#### 4.1.1 Header Information – Multiple Engines

When the RP 480i is configured to control more than one engine the status bar shows overall information for the system. If the currently shown form is focused on an individual engine the header bar narrow provides more specific information about that particular engine.

The header typically looks like this when not focusing on a specific engine on a multi engine configuration.



This variant of the header consists of the following information.

- “All Engines” – Indicates no special focus on a given engine
- A common warning/alarm banner. The entire center of the header is flashing for new unacknowledged events. It is steady lit for acknowledged events.
- Various status symbols, in this case No Events on system, not Active Panel.

#### 4.1.2 Header Information – Single Engine

If the RP480i is configured to control a single engine the Header provides more detailed information about that engine. This is also true on a RP 480i with multiple configured engines, when the operator is showing instrumentation screens for a single engine.

Example of Header when focused on a single engine.



















This variant of the header consists of the following information.

- “Engine #19 - Blocked” – The state of the Current Engine.
- Red background indicates an event is pending of at least Alarm severity.
- “Engine Start Failed” and “Switch Input #1” indicates the latest 2 events to be received by the RP 480i.

### 4.1.3 Header Status Symbols

These symbols may appear in the header bar.

 <p>No events. Either on Current Engine or entire system</p>	 <p>Active station on current engine</p>	 <p>Current Engine is in Local Mode</p>
 <p>Current Engine is in Manual Mode</p>	 <p>Current Engine is in Automatic Mode</p>	 <p>Current Engine is in Harbor Mode</p>
 <p>Current Engine is In Emergency Mode</p>	 <p>Service due for Current Engine</p>	 <p>Shutdown Override is active for Current Engine</p>
 <p>Forward gear is active on Current Engine</p>	 <p>Current Engine is in reverse gear</p>	 <p>Current Engine is in neutral gear</p>
 <p>Gear is engaged on Current Engine (unknown direction)</p>	 <p>This panel is not "Active Panel" over any engine</p>	 <p>This panel is "Active Panel" over one or more engine, but not all</p>
 <p>This panel is Active Panel over all engines</p>		

## 4.2 Instrument View

### 4.2.1 Home Page

The look of the Home Page of the RP 480i (reached by pressing the 'Home' button) looks a little different depending on:

- If the RP 480i is connected to one or several engines
- The current Home Page Layout configuration. (See the “Operator Menu” section below on how to change this setting)

#### 4.2.1.1 Home Page - Multiple Engines

When two or more engines are connected to the RP 480i, the Home Page displays an overview of all of the engines. In this layout each engine can be pressed to bring up all instrument pages for that engine in full screen.

The picture below shows the Home Page for a dual engine setup with Home Page Layout set to Dual.



When the RP 480i is connected to more engines than can be displayed on one screen, the Home Page is providing navigation buttons to move around.

See the picture below for example of this, where the Home Page Layout is set to Quad on an RP with six connected engines. Notice the “Next” button.



#### 4.2.2 Home Page - Single Engine

When the RP 480i is connected to a single engine there's no actual home page. Instead the RP assigns the first page of the connected engine as the position you reach when pressing the Home Button on the Panel. This means that the engine is always displayed in "Focused Engine view". (See below)



It is possible to configure the RP 480i to use Dual or Quad as Home Page Layout with just one engine connected, even though it may not be used often.

#### 4.2.3 Focused Engine View

It is possible to view all available instrumentation pages for each engine on the RP 480i. To enter this mode, press on an engine in the Home Page and the first engine page will be shown full screen for that engine.



If the RP is configured with Home Page Layout set to Single, the RP 480i automatically shows the "Focused Engine View" for that engine when Home Page is requested.

The operator can cycle through these pages by pressing on the left or right hand side of the screen. These "touch regions" are not visible, instead a fading arrow symbol is shown when pressed. If reaching the end of the available pages on the engine, consecutive presses will cycle around to the first or the last page depending on direction.

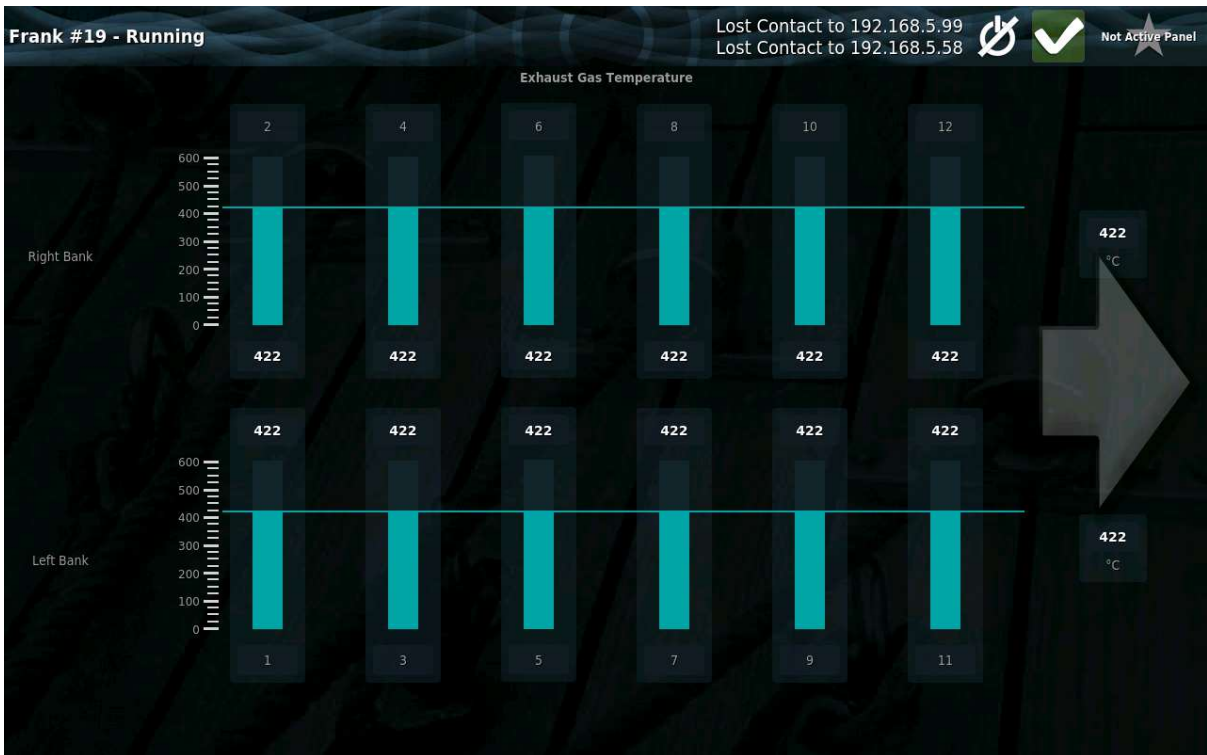

Instead of cycling through pages as described above, the center of the page can be pressed to bring up a Select Page dialog.

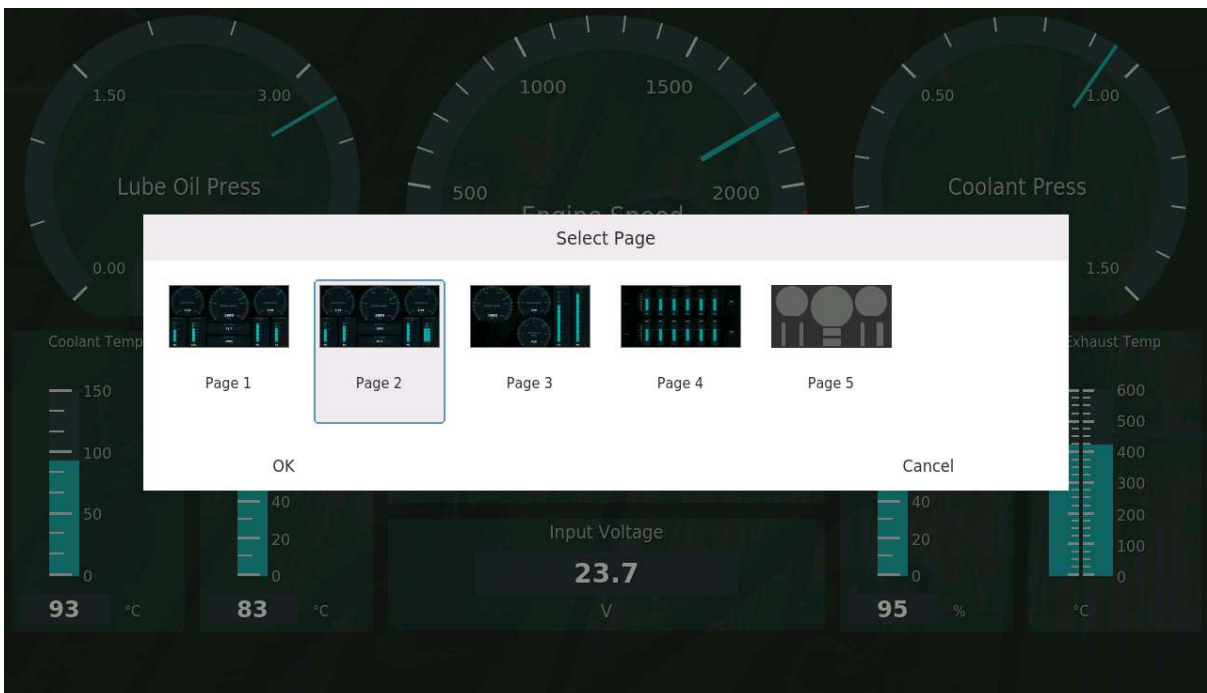

Select a page and press OK.

## 5 Start and Stop of engines

To start or stop an engine from the RP 480i, a few preconditions need to be met. Some of which depend on how the RP 480i has been configured and some relate to current runtime situations.

Configuration Requirements		Comment
Station Priority	Must be 1 or 2	A priority 3 station cannot start or stop engines.
Start/Stop Buttons	Must be enabled	Start and Stop might still be possible if the RP has been configured for external buttons.
<b>Miscellaneous</b>		
DCU Operation Mode	Must not be in Local Mode	
RP in Command	The RP must be in Command (a.k.a Active Station) of the DCU	

From here on these conditions are believed to be met. When attempting to start or stop an engine and something is missing, a message is given describing the situation.

When attempting to start or stop an engine on a Priority 2 station that is currently not in Command, a Request Command dialog box is displayed.

### 5.1 Start an engine - One connected DCU

Press the Start Button to start the engine.

If the DCU is configured to perform “Latched Start” a confirmation dialog is shown. Press on the Start button on the dialog to confirm the start attempt.

If the DCU is configured to perform “Hold to Start” the start attempt will initiate directly when pressing down the start button. Keep pressing the button until the engine has started. If releasing the button before the engine has started it aborts the start attempt.

### 5.2 Stop an engine - One connected DCU

Press the Stop Button to stop the engine.

If the DCU is configured to perform “Latched Start” a confirmation dialog is shown. Press on the Stop button on the dialog to confirm the stop attempt.

If the DCU is configured to perform “Hold to Start” the stop attempt will initiate directly when pressing down the stop button. Keep pressing the button until the engine has stopped. If releasing the button before the engine has stopped it aborts the stop attempt.

### 5.3 Start and Stop an engine - Multiple connected DCUs

Press the start or stop button to show all connected engines. Select the desired engine by pressing it and then click the start or stop button again to carry out the attempt.

If the DCU is configured to perform “Hold to Start” , keep pressing the button until the engine has started or stopped.

If the DCU is configured to perform “Latched Start” the operation is initiated immediately with no need to keep pressing the button. No confirmation dialog is shown.

### 5.4 Start and Stop multiple engines simultaneously

Select more than one engine in the Start Engine (or Stop Engine) form before pressing the Start or Stop button.

## 6 Alarm List

The Alarm List is a page dedicated to showing and managing events. Events shown here originate either from the connected engines or from the RP 480i itself.

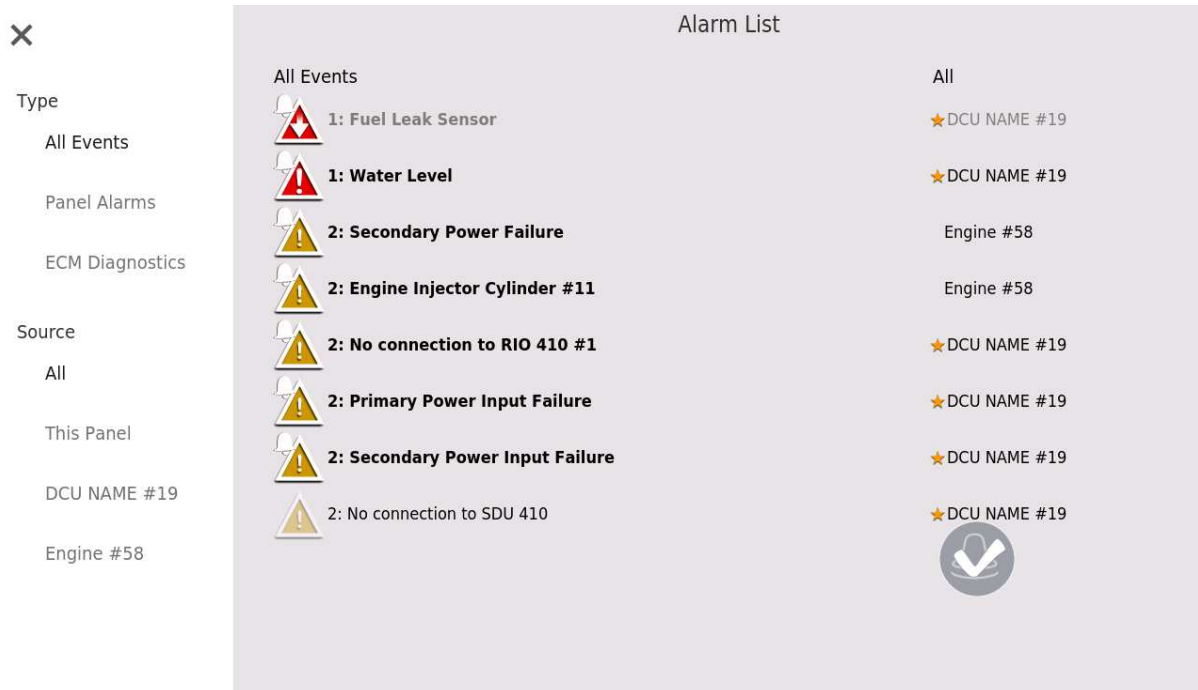

The Alarm List is accessed from any location by pressing the Alarm List button.

The page is divided in two distinct sections. The Filter Area and the Event Area. The Filter Area allows the events to be filtered to only show certain types of events and/or from certain sources. The Event area is the larger area to the right where events are shown.

### 6.1 Filter Section

In this area there are two individual filters that can be assigned to limit the events shown in the Event Area.

One of three choices in the Type section are available:

- **All Events**  
This choice indicates no filtering of shown events based on type. This is the default choice for this section.
- **Panel Alarms**  
Limit the Alarm List to only show events that are classified as Panel Alarms. Any event not originating from an ECM falls under this category, for example events produced by a DCU based on configure diagnostic rules.
- **ECM Diagnostics**  
Only show events that are reported by an ECM.

In the Source section one of at least three choices are available:



- **All**  
Show events from all sources. This is the default choice for this section.
- **This Panel**  
Only show events that originate from the RP 480i itself.
- **Engine 1**  
Only show events that originate from this particular engine.
- **Engine 2**  
Only show events that originate from this particular engine.

Each engine connected to the RP 480i is selectable from this list.

One filter per category, type and source, can be active at the same time limiting the events shown both based on their type as well as the source.



When (re)entering the Alarm List page any previous filters are always reset to show everything.

## 6.2 Event section

Each event is shown as an item in a vertical list. On the left side of the event is an icon displayed providing some basic information about the event. To the right of the icon here is a text section, providing more detailed information about the event itself.

Alarm List













All Events	All
<b>1: Fuel Leak Sensor</b>	★ DCU NAME #19
<b>1: Water Level</b>	★ DCU NAME #19
<b>2: Secondary Power Failure</b>	Engine #58
<b>2: Engine Injector Cylinder #11</b>	Engine #58
<b>2: No connection to RIO 410 #1</b>	★ DCU NAME #19
<b>2: Primary Power Input Failure</b>	★ DCU NAME #19
<b>2: Secondary Power Input Failure</b>	★ DCU NAME #19
<b>2: No connection to SDU 410</b>	★ DCU NAME #19

This list is split into two columns. The first column shows event details and the second is providing information about the source.



The column headers in the Event Area are updated to reflect any active filtering. For example if the Type filter is set to Panel Alarms, the left column headers reads “Panel Alarms”

The event icon is indicating both the severity and the acknowledgment status of the event. Events that are yet to be acknowledged have a small bell in the top left corner. Already acknowledged events do not show the bell symbol, and the icon itself is

Unacknowledged	Acknowledged	Description
		Lowest severity.
		Currently only used for J1939 DM53 type events. Lowest severity.
		Event categorized as Warning severity.
		Event categorized as Alarm severity.
		Event categorized as Derate (a.k.a Load Reduction) severity.
		Highest severity event. Event categorized as Shutdown. An event of this severity will in normal cases produce an automatic shutdown of the engine.

The event text provides additional information about the event apart from the text itself. When the text is printed in boldface, the event is unacknowledged.

When the event is inactive the text is printed in gray. If the event is in an active state the text is painted in black.

Any event in the alarm list can be selected by pressing it. Selecting an event highlights the event and it expands to show one more line of text. Here additional information about the event is shown if available.



### 6.3 Acknowledgement of events

It is possible to Acknowledge an individual event or attempt to acknowledge all events in one operation. It is always possible to acknowledge events originating from the RP 480i itself. When attempting to acknowledge engine events the local configuration of the RP 480i may block this ability or require Command (Active Panel) to carry out the operation.

Central to this is the Acknowledge Button shown in the Event section of the Alarm List



To acknowledge a single event, select the event in the list and click (press and release quickly) the Acknowledge button.

To acknowledge all events press and hold the acknowledge button for at least 1 second. Depending on the local configuration panel, this operation affects only the visible events on the screen or all events.



When attempting to acknowledge events the RP 480i provides detailed feedback in case there are reasons why the operation cannot be carried out. For example, if this Station is not in Command, a dialog is shown to request this.

## 7 Operator Menu

The Operator Menu provides a number of configuration options that controls the look and feel of the panel. This menu is accessed by pressing on the Home Button when currently looking at the Home Page.



As the Home Button brings you to the Home Page of the RP 480i, consecutive presses on this button lead to the Operator Menu independent of where you started from.

This menu does not require any pin code or password to access.

### 7.1 Quick Controls

This is the default menu page shown when entering the Operator menu. Here a number of frequently used settings have been combined to give quick access.

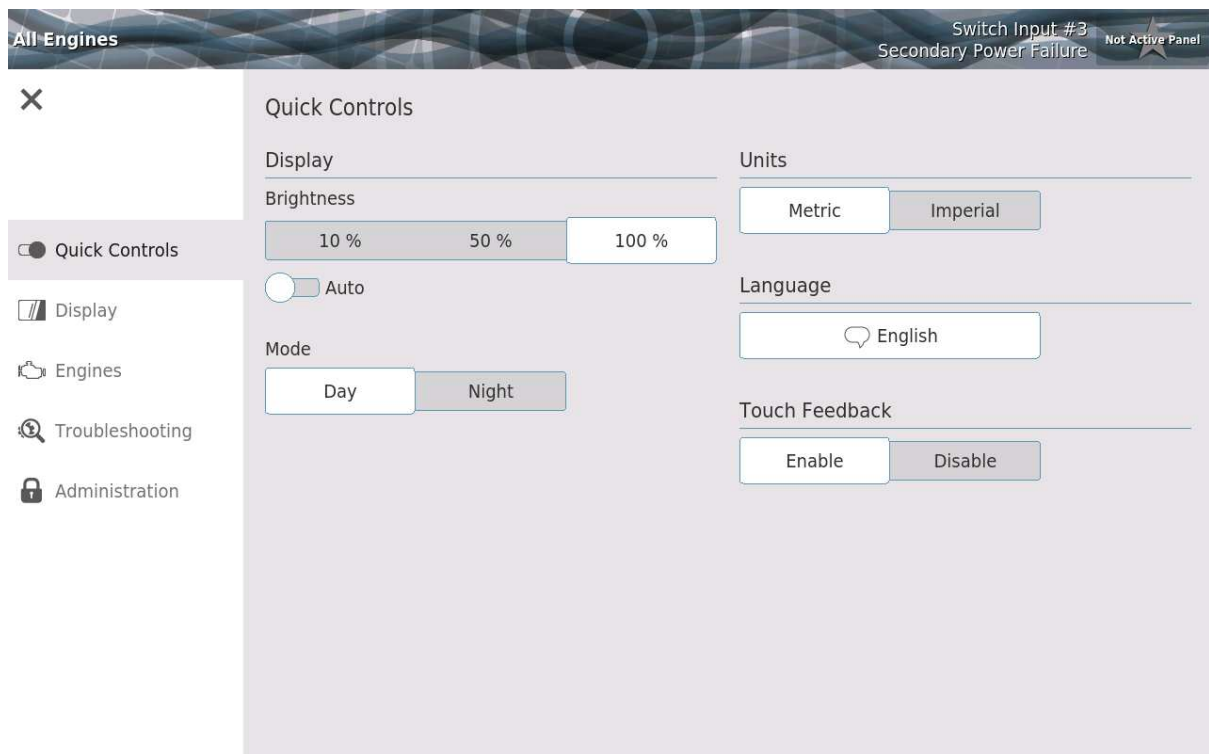

#### 7.1.1 Display

<b>Brightness</b>	
Brightness selector	Manually adjust the backlight brightness. 10%, 50% or 100%
Auto	The backlight brightness is adjusted automatically.
<b>Mode</b>	
Day	Colors optimized for daylight.

Brightness	
Night	Colors optimized for use in dark environments.

### 7.1.2 Units

Use Metric or Imperial units when displaying measurements.

### 7.1.3 Language

Select operator language from a list.

Language						
English	Français	Español	Italiano	Deutsch	Nederlands	Русский
Polski	Norsk	中文 (简体)	中文(繁體)	日本語	Português	tiếng Việt
한국어						
OK			Cancel			

### 7.1.4 Touch Feedback

Enable or Disable button beeps when pressing the touch screen or the physical buttons.

## 7.2 Display

This menu page contains configuration options relating to visual appearance.

✕

Quick Controls

**Display**

Engines

Troubleshooting

Administration

### Display

**Brightness**

10 % 50 % 100 %

Auto

**Mode**

Day Night

**Clean Screen**

Clean Screen

**Wallpaper**

Change

**Home Page Layout**

Layout

Single Dual Quad

**Engine Order**

Change

### 7.2.1 Brightness

This is the same setting as described for the Quick Controls section.

### 7.2.2 Mode

This is the same setting as described for the Quick Controls section.

### 7.2.3 Clean Screen

This command sets the RP 480i in a special state where it does not react to physical key-presses or touch operations. This function is used when cleaning the front panel of the RP 480i to avoid unwanted side-effects when wiping the screen and buttons.

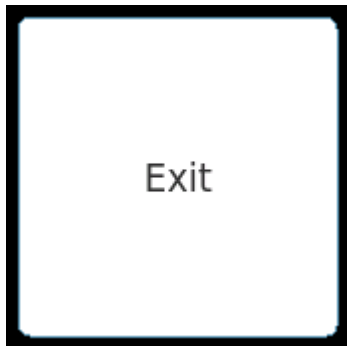

To exit this mode, press and hold the Exit button until its progress bar reaches the end.



Remember to deactivate the Clean Screen function once you're done cleaning the screen.

### 7.2.4 Wallpaper

Allows changing of the wallpaper. The wallpaper is used as a backdrop for instrumentation pages.

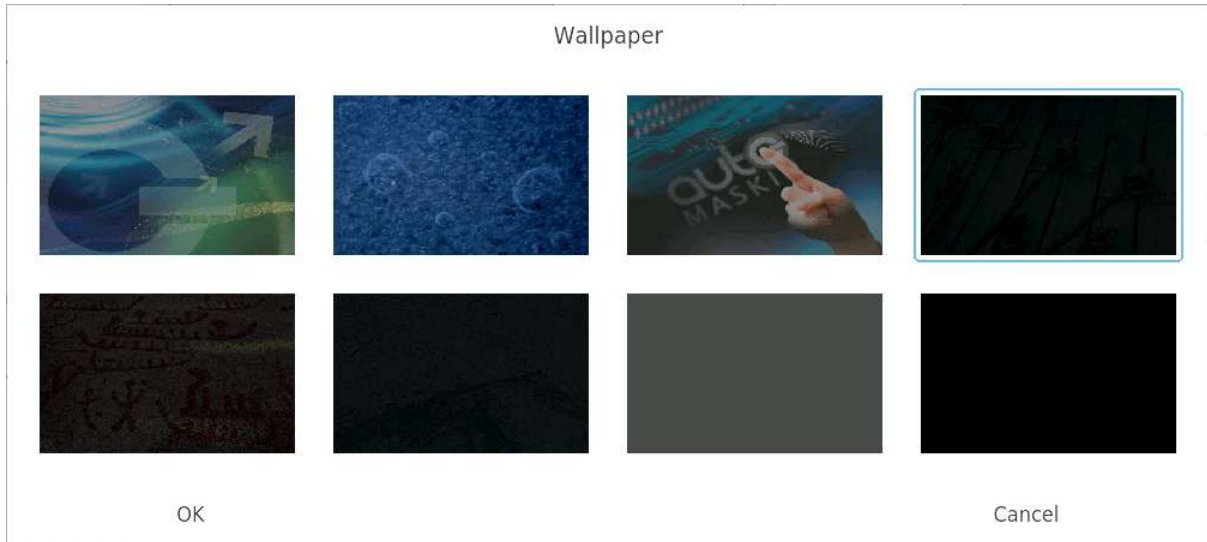

Select a wallpaper and press OK. Press the Home Button to inspect the new look.

### 7.2.5 Home Page Layout

This section defines how engines are displayed on the Home Page. This setting is mostly useful with more than one connected engine.

Home Page Layout	
Single	Show each engine in full screen.
Dual	Show two engines side-by-side on each page.
Quad	Show up four engines in a 2x2 grid on each page.

### 7.2.6 Engine Order

Allows rearrangement of the order in which engines are shown on the Home Page. This function is only useful if more than one engine is connected to the RP 480i.

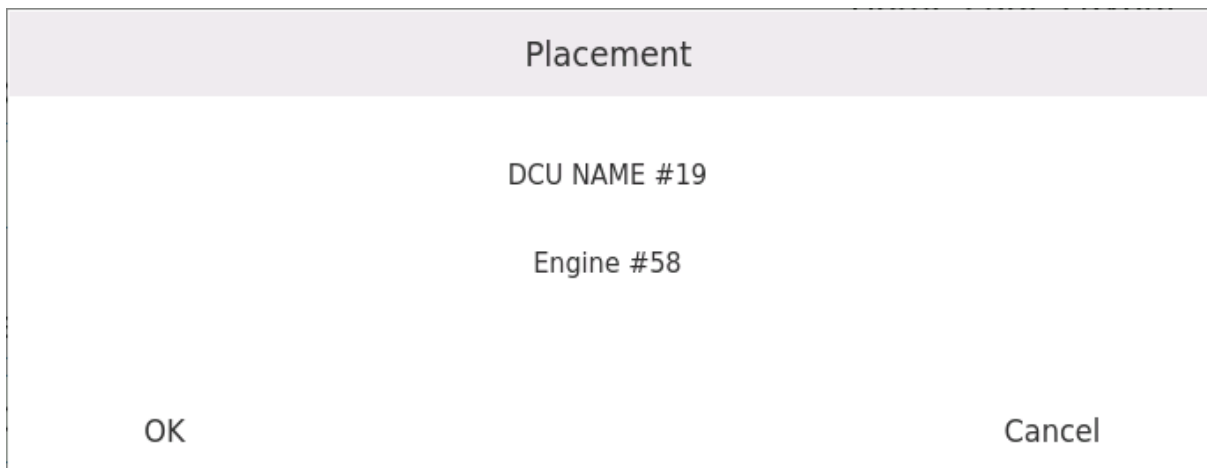

The dialog shows a list of all connected engines. The order of this list represents the order in which the engines are shown in the Home Pane. To change the order of the list drag and drop one engine to a new position in the list. Press OK to confirm the new order.

## 7.3 Engines

This menu page provides access to functions specific to an individual engine.

### 7.3.1 Engine Selection

With more than one engine connected to the RP 480i an engine selection page is shown to allow selection of which engine to focus on.

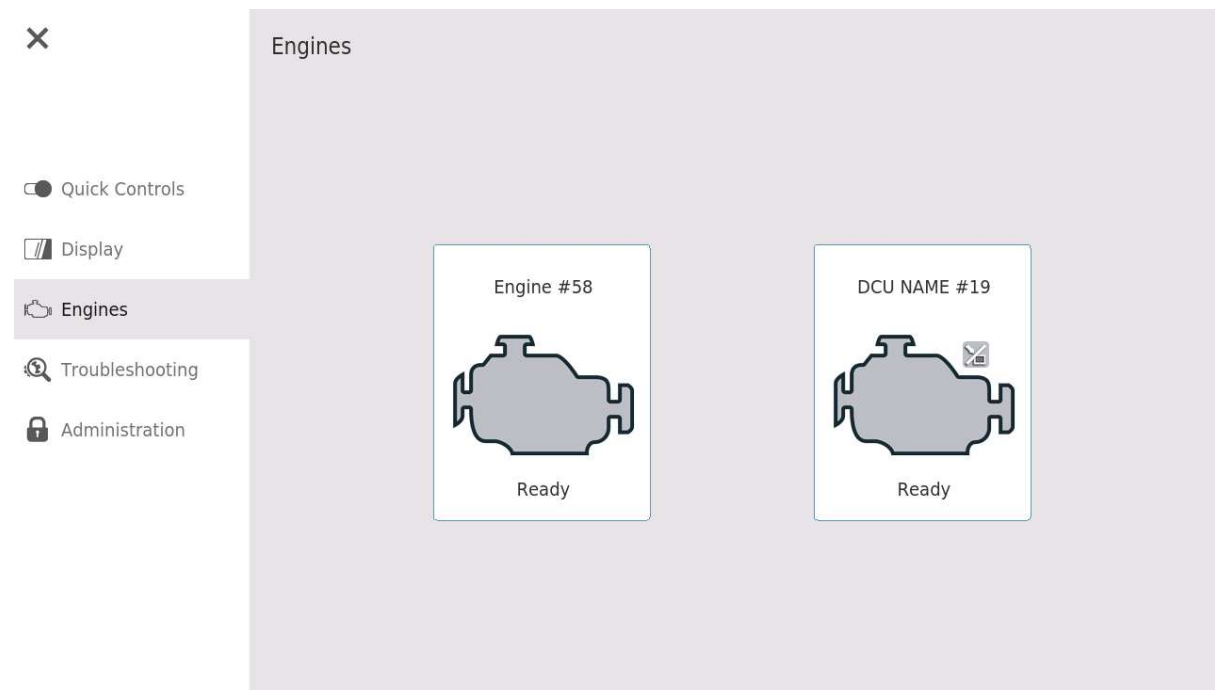

By pressing any of the engines a menu page providing functions specific to the chosen engine is displayed.



The icons shown for each connected engine provides some status information about each engine. For example, the engine state and operation mode is indicated.

If the RP 410i is connected to a single engine the engine selection step described above is not in use. Instead the Engines menu page leads directly to the engine specific functionality.

### 7.3.2 Engine Specific Functionality

The functions available for the selected engine depends mainly on what functions have been enabled on the corresponding DCU. The picture below shows an engine where all possible functions are made available on the DCU.



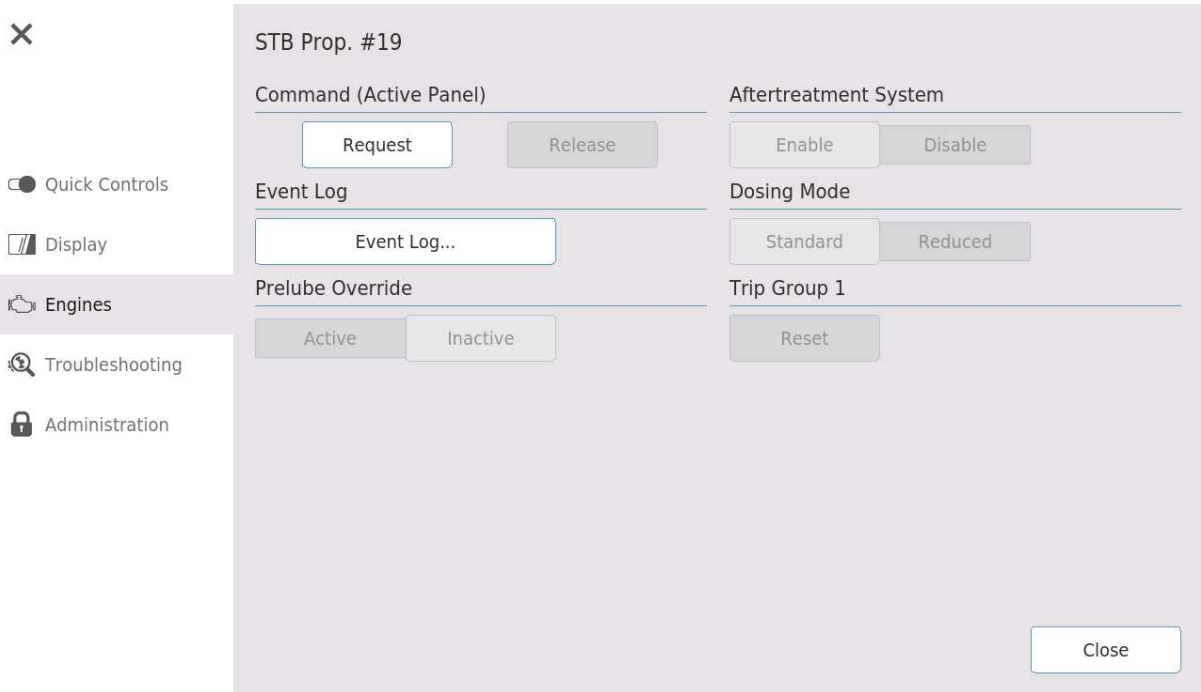

Most of the functions require the RP 480i to be Active Panel in order to be carried out. If a function is available for the current engine, but requires Active Panel, the buttons are disabled (grayed out) unless the RP 480i is Active Panel.

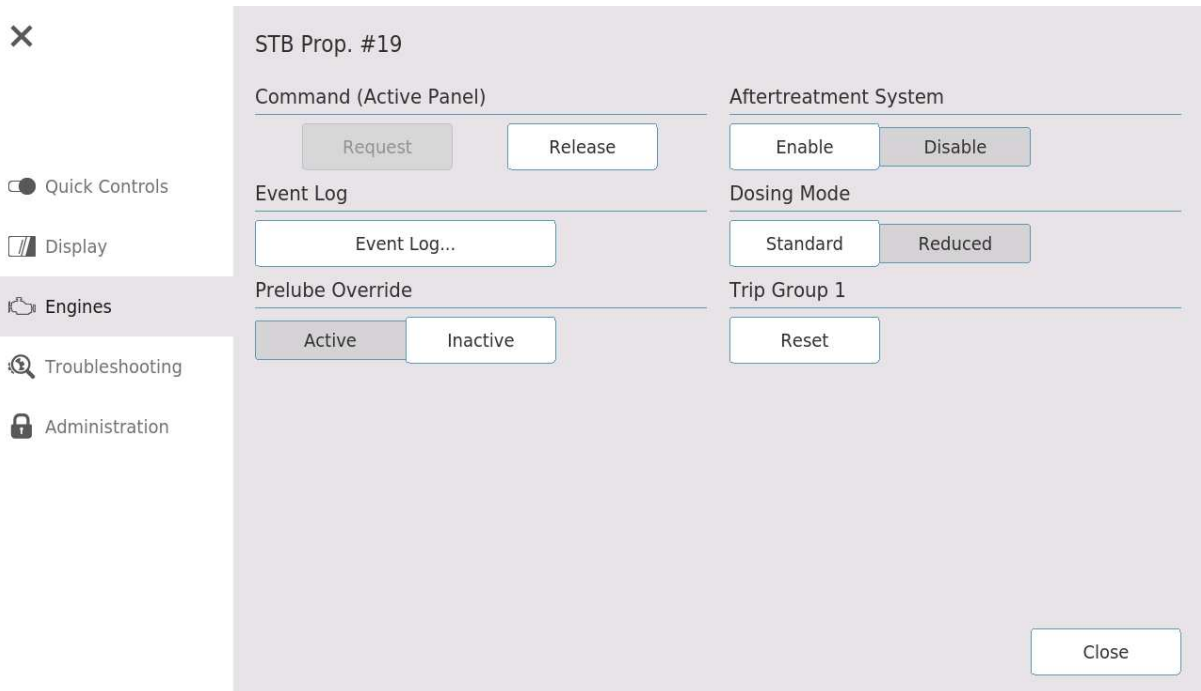

In the picture above, the RP 480i is Active Panel for Engine #19. Notice that the functions for that engine are now available.

Function	Description	Requires Active Panel
Command (Active Panel)	Request and Release Command for current engine	N/A
Event Log	Display the Event Log for Current engine.	No
Prelube Override	Activate to skip the prelube sequence the next time the engine is started.	Yes
Aftertreatment System	Manual activation and deactivation of the engine aftertreatment system.	Yes
Dosing Mode	Manual selection of the dosing mode used by the aftertreatment system.	Yes
Trip Group 1	Sends a reset command to the engine for Trip Group 1	Yes

## 7.4 Troubleshooting

This page provides a general overview of the status of the panel.

✕

Quick Controls

Display

Engines

**Troubleshooting**

Administration

### Troubleshooting

**This Panel**

Input Voltage 23.1 V

Button Test

I/O

I/O #1	Input	Night Theme	Open
I/O #2	Input	Operator Lock	Open
I/O #4	Input	Silence Buzzer	Open
I/O #6	Output	Active Panel	Inactive
I/O #8	Output	Diagnostics in Alarm List	Inactive

**Communication**

STB Prop. #19	192.168.5.119	Online
エンジン #49	192.168.5.49	Online
Engine #58	192.168.5.58	Online

**Diagnostics**

CPU Load 8.50 %

### 7.4.1 This Panel

This section provides status and aid for troubleshooting for I/O connected to the RP 480i.

#### Input Voltage

The current input voltage can be inspected.



The reported Input Voltage is a measurement performed by the RP 480i itself on its local supply.

### Button Test

This function can be used to verify the four buttons on the RP 480i are working properly.

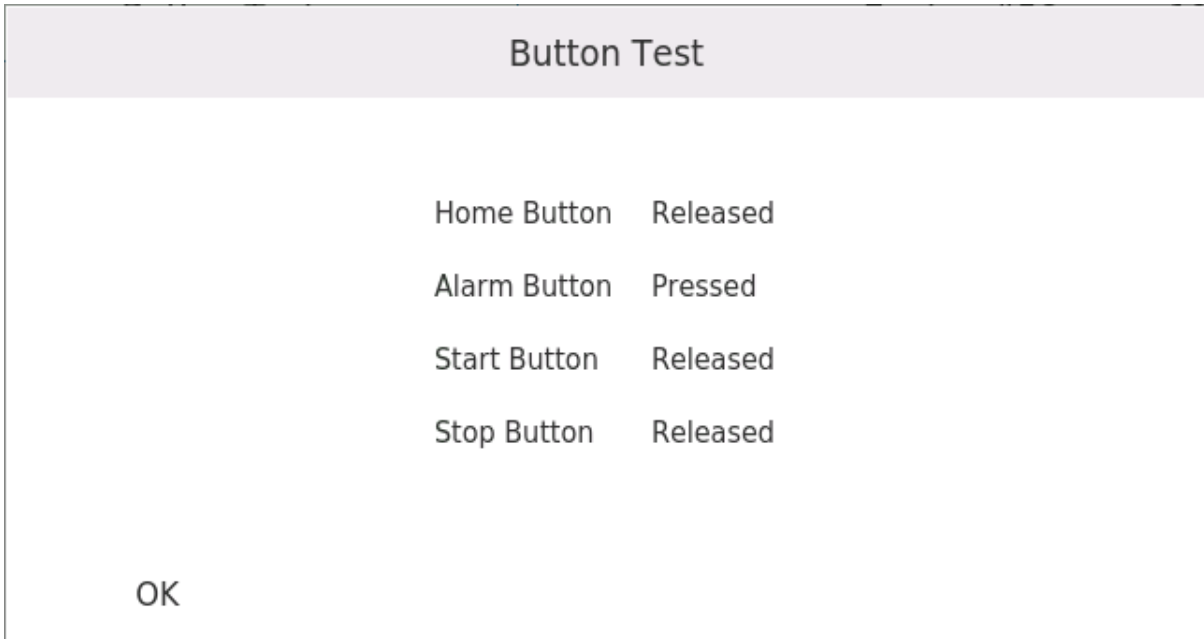

By pressing and releasing each button the expected status can be inspected. In the picture above the Alarm Button was held down at the time of the capture.



While the Button Test dialog is active it intercepts all button events. It is safe to press and release all the four buttons without causing any unwanted side effects.

To exit the dialog press the OK label.

### I/O

This section displays all local discrete I/Os enabled on the RP 480i. The I/O identifier, its direction (input or output), the function and the current status is displayed.

### 7.4.2 Communication

In this section, a list of all connected engines are shown with their name, IP address and the current status. (Offline or Online)

### 7.4.3 Diagnostics

The CPU Load measurements give a general indication about the current workload for the RP 480i's CPU.

## 7.5 Administration (User Accessible)

This page provides general information as well as how the RP 480i is configured. It also allows an administrator to gain access to the administration section of the Menu.

**Administration**

This Panel		Configuration	
IP Address	192.168.5.62	General	
MAC Address	00:0E:C6:87:72:01	Local Installation	No
Hardware Version	Unknown	Panel Location	Other
Serial Number	Unknown	Disable DCU Events	No
Software Version	3.11B5 (to be)	Start/Stop Buttons	Enabled
<b>Engines</b>		Active Panel	
STB Prop. #19	192.168.5.119	Panel Priority	2
エンジン #49	192.168.5.49	Timeout	10 seconds
Engine #58	192.168.5.58	Handover at Timeout	Yes
		Acknowledge	
		Acknowledge Visible Events Only	Yes
		DCU Acknowledge	Ack. & Silence
		Without Active Panel	No
<b>Administration Menu</b>			
<input type="button" value="Log In"/>			



In case you require assistance from a representative with your RP 480i, be sure to take note (or a photo) of this page, as it might provide important information to help solve a potential issue.

For details on how to interpret the Configuration data on this page, see the Administration Menu section below in this document.

The “Log In” button is used by an administrator to access the protected configuration options of the RP 480i.

## 8 Administration Menu

This is the section where most of the local configuration is managed. In order to access the Administrations menu a PIN code is required.

From the user accessible Administrations overview menu page press the Log In button.

The image shows a dialog box titled "Enter PIN". At the top is a light gray header with the text "Enter PIN". Below the header is a white area containing a text input field. To the right of the input field is a button with a left-pointing arrow. Below these are four rows of buttons: the first row contains "1", "2", "3", and "±"; the second row contains "4", "5", "6", and "."; the third row contains "7", "8", "9", and "0"; and the fourth row contains "OK" and "CANCEL".

Input the 4 digit admin PIN code and press OK.



If you fail to input the correct PIN code, the PIN code dialog provides a 5 digit encrypted number. If you can't remember your PIN code, take note of this encrypted number and contact your representative for help on how to restore access.

### 8.1 This Panel

In this page basic configuration of the RP 480i is managed.

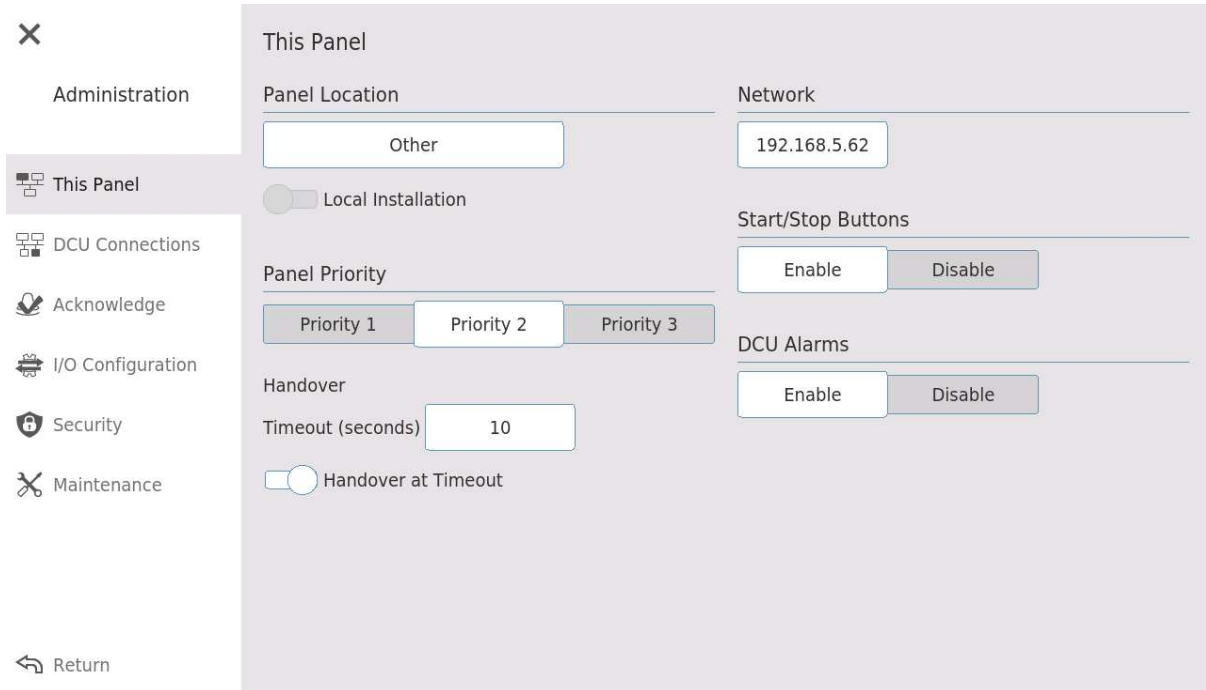

### 8.1.1 Panel Location

Assigns a Panel Location to the RP 480i. This is mainly used to identify the station with respect to Command requests from other remote panels in a system.

Local Installation is a specialized mode of operation that can be enabled to allow the RP 480i to mirror the behavior of a DCU. This can be used to locate a RP 480i as the main display for an engine in the Engine Room. This option can only be used when the RP 480i is connected to a single engine.



It is recommended to discuss the Local Installation with an Auto-Maskin representative before enabling it due to its specialized nature.

### 8.1.2 Panel Priority

The Panel Priority settings are affecting the RP 480i's behavior in relation to Command and transfer thereof.

Priority	Description
Priority 1	Highest priority station. This station will never negotiate when attempting to take Command. Unless the DCU in question is in local mode, the RP 480i takes command of the engine.
Priority 2	Standard priority station. If attempting to take Command from another remote panel, a handover question is presented on the current station in Command to either accept transfer or block it.
Priority 3	This station will and cannot take command over any engines.

The Handover settings control how this station should behave when currently in Command and another station requests to take over Command. The Timeout value specifies how long the dialog should linger on the screen in case no answer is given. The Handover at Timeout switch dictates if this station should relinquish or retain Command if the dialog times out.

### 8.1.3 Network

This is the IP address used by the RP 480i. By pressing the address it is possible to change the address.



**Important!** Make sure to assign the IP address to be on the same subnet as the DCUs you're attempting to connect to.

Example, if your DCUs have IP number 192.168.7.1 and 192.168.7.2 a good IP address for the RP 480i would be 192.168.7.201

### 8.1.4 Start/Stop Buttons

This setting controls whether the physical start and stop buttons on the RP 480i should be enabled. An information popup is given if pressing either of these buttons if disabled here.

Note, disabling the start and stop buttons does not affect any Inputs on the RP 480i configured to Start or Stop functions.

### 8.1.5 DCU Alarms

When this setting is Enabled the RP480i Alarm List will show events from all connected DCUs. If disabled, no events from any DCU are included in the alarm list.

## 8.2 DCU Connections

In this menu page the RP 480i's connections to DCUs are managed.

✕

Administration

☰ This Panel

☰ DCU Connections

👉 Acknowledge

🔌 I/O Configuration

🔒 Security

✂ Maintenance

↶ Return

DCU Connections

Engine	Type	IP Address	Version	Status	In Use
Engine #2	DCU 210E	192.168.5.102	3.11B5	OK	<input type="checkbox"/>
STB Prop. #19	DCU 410E	192.168.5.119	3.11B5	OK	<input checked="" type="checkbox"/>
O_o #24	DCU 410E	192.168.5.124	3.10B19	OK	<input type="checkbox"/>

The page is automatically updated to show a list of all available DCUs on the network.

The “In Use” switch is enabled or disabled to instruct the RP 480i to connect to a DCU.

Note, the list shows a real time reflection of the DCUs currently available on the network with one exception. In case a DCU has been previously set to In Use but is no longer available it will still show on the list. If setting such a DCU to Not In Use it will immediately be removed from the list.

### 8.3 Acknowledge

This page defines how the RP 480i should act with respect to acknowledgement of DCU events.

General - Acknowledge visible events only	
Enable	Acknowledge All only acknowledges events currently visible on the Alarm List.
Disable	Acknowledge All affects all events on the Alarm List.
DCU Acknowledge	
Not Allowed	Not possible to acknowledge any DCU events from this station.
Silence	This station can silence the Buzzer on a DCU but cannot acknowledge any events on DCUs
Ack. & Silence	Allows both silence oc DCU buzzers as well as acknowledgment of DCU events

If enabling Acknowledge without being Active Panel the RP 480i allows acknowledgement of DCU events without being in Command.



**!** **Important!** Acknowledge without being Active Panel breaks class requirements and should not be enabled in classed installations.

## 8.4 I/O Configuration

In this page local I/O functionality is managed.

The RP 480i features 8 flexible I/O interfaces and one internal relay that can be configured.

### 8.4.1 Flexible I/O

Each Flexible I/O interface can be configured to act either as a Discrete Input or Output direction interface.

Once a direction has been chosen a Function is mapped to the I/O interface.

**!** Depending on the direction of an I/O Interface, the list of available Functions change.  
The Relay is treated as an Output with respect to available Functions.

### 8.4.2 Input Functions

For any I/O configured as Input press the Function button to assign an Input Function.

I/O #1 - Input		
None	Acknowledge	Silence Buzzer
Request Active Panel	Start	Stop
Operator Lock	Night Theme	
OK		Cancel

Click on an Input Function to assign this function to the selected Input. Inputs on the RP 480i use an active-high concept. This means that when the physical interface is energized with 24 VDC the associated function is also considered active.



I/O Interface configured as Input features an internal pull-down to 0V. This means that any input that is not wired will default to inactive state.

Input Function	Description
None	No function.
Acknowledge	Acknowledge events. Any events in the alarm list that are eligible are acknowledged. This means that if the RP480i is allowed to acknowledge DCU events and is currently in Command over a given DCU those events are affected. A DCU over which the RP 480i is not in Command is unaffected.
Silence Buzzer	Silence the local RP 480i buzzer if activated. Also silences buzzers on connected DCU if the RP 480i is configured to perform this.
Request Active Panel	When activated the RP480i attempts to request command over all connected DCUs. If the RP480i is configured as a Priority 3 station this function has no practical meaning.
Start	Replicates the function of the Start Button on the front of the RP480i.
Stop	Replicates the function of the Stop Button on the front of the RP480i.
Operator Lock	When active, all operator input is blocked. Neither the touch interface nor the buttons respond to user input. An indicator is shown at the bottom right to signify this state.
Night Theme	When active, the entire user interface is using a discrete color scheme that is suitable for low ambient light conditions.

### 8.4.3 Output Functions

When an Output Function function is active any output mapped to this function is energized.

Output Functions	Description
None	No function.
Buzzer Active	Active when the Buzzer on the RP 480i is active.
Active Panel	Active when this RP 480i is in Command over at least one DCU.
Engine(s) Running	At least one connected DCU (engine) is in a running state.
All Engines Running	All connected DCUs (engines) are in a running state.
Acknowledge Button (1 second pulse)	Function generates a 1 second pulse when the acknowledge button is pressed.
Alarms in Alarm List	At least one Warning, Alarm, Load Reduction or Shutdown Event in the Alarm List.
Diagnostics in Alarm List	At least one J1939 Diagnostic Event in the Alarm

Output Functions	Description
	list.
Active Panel for xxx	Active when the RP 480i is in Command over DCU xxx. Each connected DCU is given an individual Output Function of this type.

## 8.5 Security

This section provides options relating to security aspects of the panel.

### 8.5.1 PIN

The “Change PIN” button allows changing of the current pin code.

In order to change the PIN the current pin needs to be entered first after which the new PIN can be given and confirmed.

Cyber Security

### 8.5.2 Web Server

This switch controls whether the RP should activate or deactivate its web server.

The web server is enabled by default.

### 8.5.3 SSH Server

This switch is only used for service purposes. It is recommended to keep this switch disabled at all times.

## 8.6 Maintenance

### 8.6.1 Panel Maintenance

#### Software Update

To use this function, prepare a USB stick in advance by adding the desired software update file to the USB stick and insert the stick in any USB port on the panel. There can be several different firmware update files on the USB stick but normally only one is needed.

Ask your sales representative or consult Auto-Maskin’s webpage on how to retrieve software upgrade files.

When pressing the Software Update button a dialog is shown displaying all available firmware update files on the USB stick.

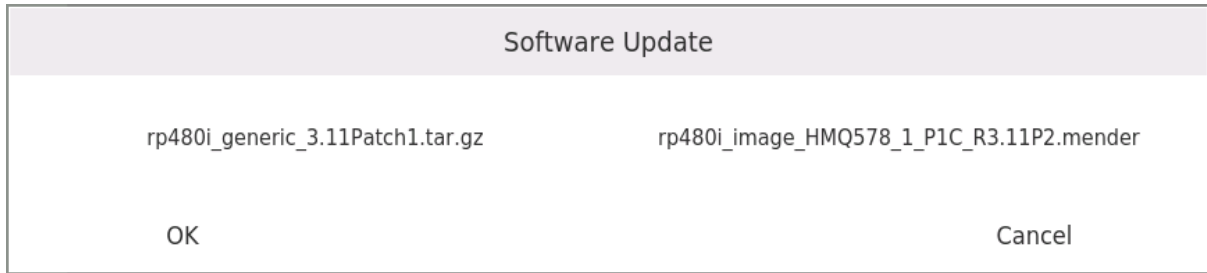

Select the desired software file to use and press OK to select it. Press Yes in the confirmation dialog to start the upgrade process.

The RP 480i supports two different file formats for firmware upgrades, either a file with the “.tar.gz” suffix or a “.mender” suffix. Either one can be used to upgrade the software, however it is recommended to use the mender-file. In the example above the USB stick holds two software files, one of each type.



**Important!** While the software upgrade process is running, don't remove the USB from the panel or turn off the power to the panel.

When the upgrade process is complete, the RP will restart. Once restarted, it is safe to remove the USB stick from the panel.



**Tip!** Make sure to double check the reported Software Version in the Administrations form to verify the upgrade took place.

### Factory Reset

Press and confirm this operation to rest all configuration done to the RP 480i to its default state.

This operation will not affect any DCU connected to the RP.